

General Notes

Time allowed **3 hours**

You must also enter your candidate number and test code on your examination script.

Only answer 10 questions

There are 16 questions, each question carries equal marks. **Use ink**, not pencil, to answer all questions.

On completion of the examination

- please collate your answer sheets into **question number order**
- complete the table to your right and secure this question paper and your answers with the tag provided

APM Project Management Qualification – Examination Paper

Candidate Number	
Exam Date	
Exam Location	
Test Code	
Reference	Sample/CPS/170317v5

Question number	Number of pages	Office use only	Question number	Number of pages	Office use only

Do not open this paper until instructed by the invigilator.

All candidate markings on the question paper will be disregarded unless specifically stated otherwise.

This question paper must not be removed from the examination room.

ALL CANDIDATES MUST COMPLETE THIS SECTION

Please enter the name of your current employer here:

This information is required in order to apply corporate discount rates where applicable.

APM will supply relevant details about your examination, including results, to your training provider.

APM may contact you from time to time with information from APM or selected third parties.

Please indicate which level of information you wish to receive

- Please send me information from APM
- Please send me information from APM and selected third parties
- Please do not send me any information

UNREGISTERED CANDIDATES MUST ALSO COMPLETE THIS SECTION

*First name

*Last name

*Email address

**All are mandatory fields in order to process your examination script and issue your results*

Answering APM Project Management Qualification questions

Please take note of the key words in each question

- List and describe:** The typical styles for answering are:
A list of requisite items, followed by equivalent number of paragraphs.
or
A number of paragraphs with embedded headers.
- Explain:** The typical style for answering this type of question is a number of sentences or paragraphs providing a coherent explanation to the question posed.
- State:** The typical style for answering this type of question is a sentence or short paragraph.
- Determine:** The typical style for answering this type of question is a numeric value, calculation or formula. Answers may appear as:
A numeric value, such as 35 days
or
A formula, workings and numeric value, such as $CPI = EV/AC$
 $CPI = 75/50 = 1.5$
or
Determination of a sequence of tasks forming the critical path and duration, such as G-E-S-M 14 days

The above styles of question may be presented in any combination as a 50 mark question.

Question 1

Learning Outcome Understand contexts and environments in which projects can be delivered

Warning This question has two parts. Answer both parts.

Question part (a) List and describe four external factors that can affect the timeline of a project.

Marks 40 marks (10 marks each)

Question part (b) Explain the purpose of using SWOT analysis to assess the context of a project.

Marks 10 marks

Question 2

Learning Outcome Understand project life cycles

Question List and describe five phases in an extended project life cycle.

Marks 50 marks (10 marks each)

Question 3

Learning Outcome Understand planning for success

Warning This question has two parts. Answer both parts.

Question part (a) Within the context of Earned Value Management, explain the term Earned Value.

Marks 10 marks

Question part (b) Explain four benefits of using Earned Value Management.

Marks 40 marks (10 marks each)

Question 4

Learning Outcome Understand project procurement

Question Within a typical procurement strategy, explain each of the following five factors:

- Make or buy decision
- Use of single, integrated or multiple providers/suppliers
- Provider/supplier selection
- Conditions and forms of contract
- Types of pricing and methods of reimbursement

Marks 50 marks (10 marks each)

Question 5

Learning Outcome Understand project scope management

Warning This question has three parts. Answer all parts.

Question part (a) Explain the term scope management.

Marks 10 marks

Question part (b) List and describe two breakdown structures used to communicate the scope of a project.

Marks 20 marks (10 marks each)

Question part (c) Explain two reasons why the scope of the project should be baselined.

Marks 20 marks (10 marks each)

Question 6

Learning Outcome Understand the principles of leadership and teamwork

Warning This question has two parts. Answer both parts.

Question statement This question focuses upon team development. Answers relating to situational leadership or personal development are inappropriate.

Question part (a) Explain what is meant by team development in a project context.

Marks 10 marks

Question part (b) List and describe, using an appropriate model, four key stages of team development.

Marks 40 marks (10 marks each)

Question 7

Learning Outcome Understand planning for success

Warning This question has two parts. Answer both parts.

Question part (a) Explain the prerequisites required for each of the following three estimating methods:

- Comparative
- Bottom up/Analytical
- Parametric

Marks 30 marks (10 marks each)

Question part (b) State four practical problems of initial estimates for a project with a long timescale.

Marks 20 marks (5 marks each)

Question 8

Learning Outcome Understand how organisations and projects are structured

Question List and describe five activities which the project sponsor performs during the project life cycle.

Marks 50 marks (10 marks each)

Question 9

Learning Outcome Understand planning for success

Warning This question has two parts. Answer both parts.

Question part (a) Explain the purpose of the Project Management Plan (PMP).

Marks 10 marks

Warning The answer to part (b) must focus on content of a PMP not the structure of the document itself (eg not table of contents, appendices, glossary etc).

Question part (b) List and describe four essential sections of a typical Project Management Plan.

Marks 40 marks (10 marks each)

Question 10

Learning Outcome Understand communication within project management

Warning Focus on addressing barriers to communication.

Question List five barriers to communication and describe how each one may be proactively managed.

Marks 50 marks (10 marks each)

Question 11

Learning Outcome Understand risk management and issue management

Question List and describe five benefits to an organisation of adopting a formal risk management process.

Marks 50 marks (10 marks each)

Question 12

Learning Outcome Understand how organisations and projects are structured

Warning This question has two parts. Answer both parts.

Question part (a) State two resource loading observations from the given histogram.

Marks 10 marks (5 marks each)

Question part (b) List and describe four actions that the project manager might take in response to the resource loading profile in the given histogram. Include the potential benefit to the project of taking each action.

Marks 40 marks (10 marks each)

The following resource histogram shows the labour resources required for a project. The capacity line indicates that there are a maximum number of 8 labour resources available to the project each week.

Resource Histogram

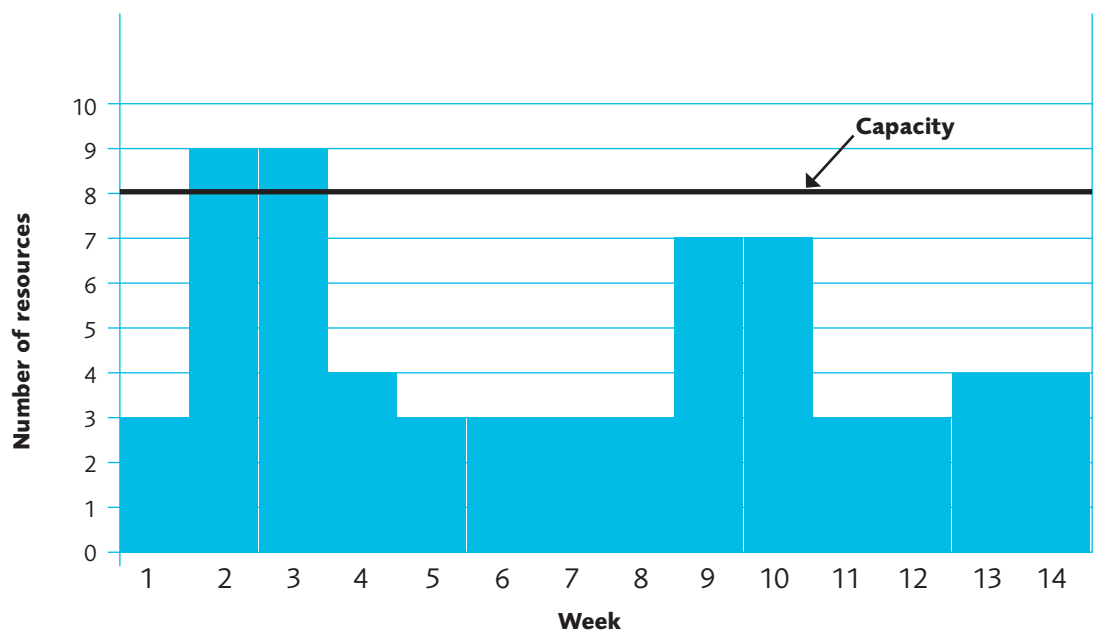

Question 13

Learning Outcome Understand contexts and environments in which projects can be delivered

Question Explain five distinct benefits to be gained from managing a group of projects as a programme, rather than as individual, unconnected projects.

Marks 50 marks (10 marks each)

Question 14

Learning Outcome Understand project quality management

Warning This question has two parts. Answer both parts.

Question part (a) Explain what is meant by the term project quality management.

Marks 10 marks

Question part (b) Explain each of the following four essential components of project quality management.

- Quality planning
- Quality assurance
- Quality control
- Continual improvement

Marks 40 marks (10 marks each)

Question 15

Learning Outcome Understand the principles of leadership and teamwork

Warning This question has two parts. Answer both parts.

Question part (a) Explain the term leadership.

Marks 10 marks

Question part (b) List four typical leadership qualities and describe how each assists in directing or supporting a project team.

Marks 40 marks (10 marks each)

Question 16

Learning Outcome Understand schedule and resource management

Warning This question has two parts. Answer both parts.
Candidates are not required to redraw the diagram in their answer.

Question part (a) For the given network diagram, determine:

- The critical path
- The duration of the project
- The task with the most free float
- The task with the least free float (ignore tasks with zero float)

Marks 20 marks (5 marks each)

Question part (b) Explain three of the following terms, including why each is important to the project manager:

- Critical path
- Finish-to-Start relationship
- Start-to-Finish relationship
- Lag
- Total float

Marks 30 marks (10 marks each)

The following network diagram shows various tasks along with their dependencies (all relationships are finish to start) and durations (in weeks).

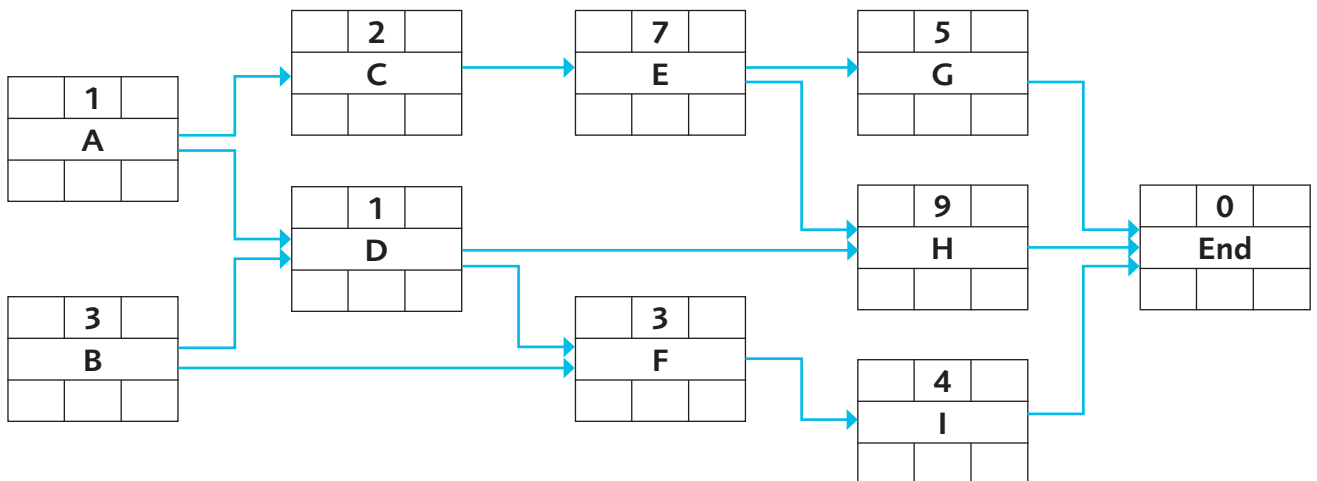

Key to network nodes:

Earliest start time	Duration	Earliest finish time
Task identifier		
Latest start time	Total float	Latest finish time

Association for Project Management

Ibis House, Regent Park
Summerleys Road
Princes Risborough
Buckinghamshire HP27 9LE

Telephone +44 (0) 845 458 1944
Facsimile +44 (0) 845 458 8807
Email qualifications@apm.org.uk
Web apm.org.uk